

Sanitary hot water

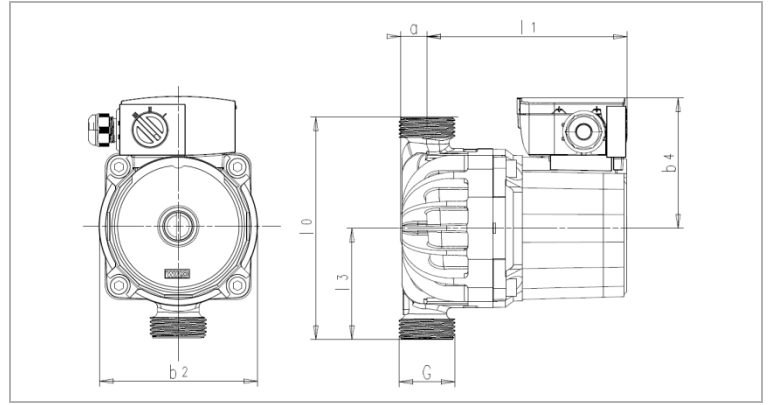

Asynchronous circulators for sanitary application

Type : ZRS Ku and NSC



Connections G3/4 " or G1 " :

- > Maximal torque : 40 Nm
- > Screwed on minimum 3 threads
- > Gasket (EP856, EP80/2 or equivalent)
 - Ø24 x Ø16 x 2.1 (G3/4")
 - Ø30 x Ø21 x 2.1 (G1")

		n l / min	P1 W	I A	Capacitor µf / VDB
ZRS../2 Ku NSC10..	max	2100	48	0,21	1,6 / 400
		1860	32	0,15	
	min	1300	19	0,10	
ZRS../4 Ku NSC15..	max	2600	55	0,24	2 / 400
		2500	39	0,18	
	min	2100	26	0,12	
ZRS../6 Ku NSC25..	max	2450	85	0,38	2,6 / 400
		2000	63	0,29	
	min	1450	45	0,21	
ZRS../7 Ku NSC30..	max	2650	115	0,51	3,5 / 400
		2400	86	0,40	
	min	1900	62	0,29	

	Thread	Dimensions					
	G	I0	I1	I3	a	b2	b4
ZRS12/2 Ku – NSC10-12	3/4"	130	116,5	65	15,5	92,5	72,5
ZRS12/4 Ku – NSC15-12			116,5				72,5
ZRS12/6 Ku – NSC25-12			116,5				76
ZRS12/7 Ku – NSC30-12			129,5				76
ZRS15/2 Ku – NSC10-15	1"	130	116,5	65	15,5	92,5	72,5
ZRS15/4 Ku – NSC15-15			116,5				72,5
ZRS15/6 Ku – NSC25-15			116,5				76
ZRS15/7 Ku – NSC30-15			129,5				76

Asynchronous circulators for sanitary application

Type : ZRS Ku and NSC

ZRS ../-3 Ku

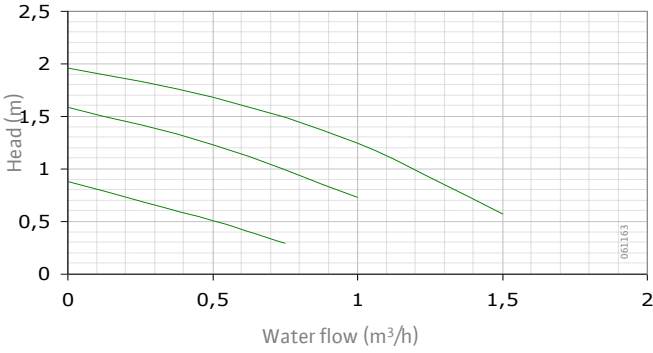

ZRS ../-4-3 Ku

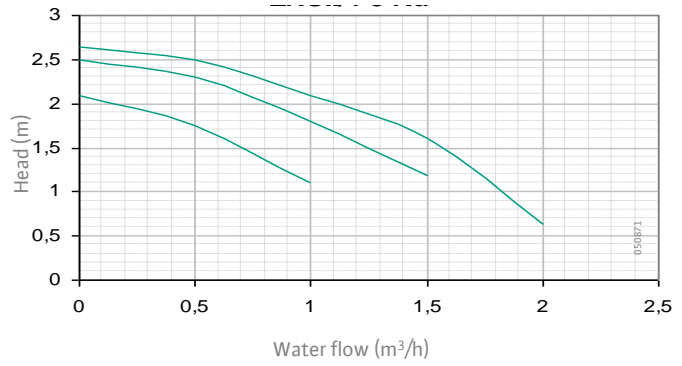

ZRS ../-6-3 Ku

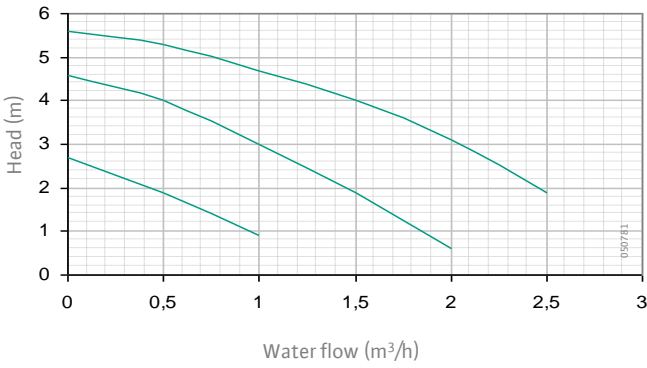

ZRS ../-7-3 Ku

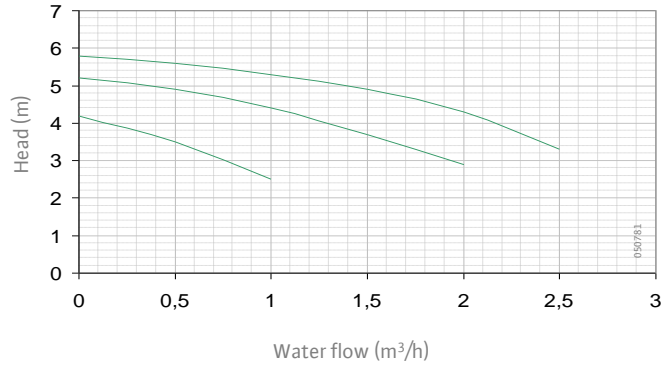



Wilointec

50 av. Casella
F-18700 Aubigny sur Nère
Tel : +33 2 48 81 62 62
Fax : +33 2 48 58 20 29
information@wilointec.com

Sales & Marketing Director

Vincent Fleurier
Tel : +33 2 48 81 62 74
Fax : +33 2 48 58 20 29
vincent.fleurier@wilointec.com

Sales Administration Manager

Véronique Martin
Tel : +33 2 48 81 62 75
Fax : +33 2 48 58 20 29
veronique.martin@wilointec.com

Sales Manager France & Spain

Robert Carre
Tel : +33 2 48 81 62 72
Fax : +33 2 48 58 20 29
robert.carre@wilointec.com

Sales Manager Italy

Dario Frazza
Tel : +39 335 762 6181
Fax : +39 059 286 0855
dario.frazza@wilointec.com

Sales Manager Subsidiaries

Gilles Moulin
Tel : +33 2 48 81 62 25
Fax : +33 2 48 58 20 29
gilles.moulin@wilointec.com

Sales Manager Germany

Thomas Merscheim
Tel : +49 172 352 3933
Fax : +49 231 410 2578
thomas.merscheim@wilo.de

Sales Manager UK

Kevin Padmore
Tel : +44 776 801 8879
Fax : +44 128 373 2380
kevin.padmore@wilointec.com

Sales Manager Benelux

Ronald Rijkhoff
Tel : +31 653 126 749
Fax : +31 251 215 214
ronald.rijkhoff@wilo.nl